



INVOIC Invoice Message

EDIFACT/D01B/INVOIC

Version: 1.0

Company:	Simplot Australia
Publication:	10/4/2023
Modified:	10/4/2023

Table of Contents

INVOIC	Invoice message	1
	Branching Diagram - 1	4
	Branching Diagram - 2	5
	Branching Diagram - 3	6
UNH	MESSAGE HEADER	7
BGM	BEGINNING OF MESSAGE	9
DTM	DATE/TIME/PERIOD	10
RFF	REFERENCE	11
NAD	NAME AND ADDRESS	12
RFF	REFERENCE	13
LIN	LINE ITEM	14
PIA	ADDITIONAL PRODUCT ID	15
IMD	ITEM DESCRIPTION	17
QTY	QUANTITY	18
MOA	MONETARY AMOUNT	19
PRI	PRICE DETAILS	20
UNS	SECTION CONTROL	21
CNT	CONTROL TOTAL	22
MOA	MONETARY AMOUNT	23
UNT	MESSAGE TRAILER	24

INVOIC Invoice message

Message Status=13

Definition: A message claiming payment for goods or services supplied under conditions agreed between the seller and the buyer. The United Nations Standard Invoice Message, with correct data qualification, serves also as the specification for Debit Note and Credit Note messages. Throughout this document, the reference to 'Invoice' may be interpreted as conveying the wider meaning of 'Invoice/Credit Note/Debit Note'.

Heading:

<u>Pos</u>	<u>Tag</u>	<u>Segment Name</u>	<u>Status</u>	<u>Rep</u>	<u>Notes</u>	<u>Usage</u>
0010	UNH	MESSAGE HEADER	M	1	N1/0010	Must use
0020	BGM	BEGINNING OF MESSAGE	M	1	N1/0020	Must use
0030	DTM	DATE/TIME/PERIOD	M	35	N1/0030	Must use
0120		Segment Group 1	C	99999	N1/0120	Used
0130	RFF	REFERENCE	M	1	N1/0130	Must use
0220		Segment Group 2	C	99	N1/0220	Used
0230	NAD	NAME AND ADDRESS	M	1	N1/0230	Must use
0270		Segment Group 3	C	9999	N1/0270	Used
0280	RFF	REFERENCE	M	1	N1/0280	Must use

Detail:

<u>Pos</u>	<u>Tag</u>	<u>Segment Name</u>	<u>Status</u>	<u>Rep</u>	<u>Notes</u>	<u>Usage</u>
1090		Segment Group 26	C	9999999	N2/1090	Used
1100	LIN	LINE ITEM	M	1	N2/1100	Must use
1110	PIA	ADDITIONAL PRODUCT ID	C	25	N2/1110	Used
1130	IMD	ITEM DESCRIPTION	C	99	N2/1130	Used
1150	QTY	QUANTITY	C	5	N2/1150	Used
1250		Segment Group 27	C	99	N2/1250	Used
1260	MOA	MONETARY AMOUNT	M	1	N2/1260	Must use
1330		Segment Group 29	C	25	N2/1330	Used
1340	PRI	PRICE DETAILS	M	1	N2/1340	Must use

Summary:

<u>Pos</u>	<u>Tag</u>	<u>Segment Name</u>	<u>Status</u>	<u>Rep</u>	<u>Notes</u>	<u>Usage</u>
2170	UNS	SECTION CONTROL	M	1	N3/2170	Must use
2180	CNT	CONTROL TOTAL	C	10	N3/2180	Used
2190		Segment Group 50	M	100	N3/2190	Must use
2200	MOA	MONETARY AMOUNT	M	1	N3/2200	Must use
2320	UNT	MESSAGE TRAILER	M	1	N3/2320	Must use

Simplot Example Document:

```

UNA:+.? '
UNB+UNOA:3+Simplot EDI Id:ZZ+Partner EDI Id:ZZ+231004:1407+364795++++1'
UNH+364795+INVOIC:D:01B:UN:EAN010'
BGM+388:::TAX INVOICE+Invoice Number +9'
DTM+137:202310041405:203'
RFF+ON:PO Number '
RFF+AAK:8878130'
NAD+BY+Buyer::9'
NAD+ST+Ship To::92'

```

NAD+SU+Supplier Id::92'
RFF+AMT:98070579609'
LIN+1++19310081011542:SRV'
IMD+F+:::Product Description'
QTY+47:216'
MOA+128:8796.43'
MOA+203:8796.43'
MOA+369:0'
PRI+1E:40.7242'
LIN+2++19310081118449:SRV'
IMD+F+:::Product Description'
QTY+47:72'
MOA+128:4254.77'
MOA+203:4254.77'
MOA+369:0'
PRI+1E:59.094'
LIN+3++19310081118999:SRV'
IMD+F+:::Product Description'
QTY+47:126'
MOA+128:4461.12'
MOA+203:4461.12'
MOA+369:0'
PRI+1E:35.4057'
LIN+4++19310139125474:SRV'
IMD+F+:::Product Description'
QTY+47:63'
MOA+128:1685.95'
MOA+203:1685.95'
MOA+369:0'
PRI+1E:26.7611'
LIN+5++19310139125504:SRV'
IMD+F+:::Product Description'
QTY+47:112'
MOA+128:6968.36'
MOA+203:6968.36'
MOA+369:0'
PRI+1E:62.2175'
LIN+6++19310139125634:SRV'
IMD+F+:::Product Description'
QTY+47:112'
MOA+128:8159.7'
MOA+203:8159.7'
MOA+369:0'
PRI+1E:72.8545'
LIN+7++19310081126901:SRV'
IMD+F+:::Product Description'
QTY+47:160'
MOA+128:4977.41'
MOA+203:4977.41'
MOA+369:0'
PRI+1E:31.1088'
LIN+8++19310139128307:SRV'

IMD+F+++::Product Description'
QTY+47:168'
MOA+128:7845.78'
MOA+203:7845.78'
MOA+369:0'
PRI+1E:46.7011'
LIN+9++19310081127168:SRV'
IMD+F+++::Product Description'
QTY+47:28'
MOA+128:1861.46'
MOA+203:1861.46'
MOA+369:0'
PRI+1E:66.4807'
LIN+10++19310081131677:SRV'
IMD+F+++::Product Description'
QTY+47:72'
MOA+128:4254.77'
MOA+203:4254.77'
MOA+369:0'
PRI+1E:59.094'
LIN+11++19310081419546:SRV'
IMD+F+++::Product Description'
QTY+47:84'
MOA+128:5584.38'
MOA+203:5584.38'
MOA+369:0'
PRI+1E:66.4807'
LIN+12++19310081451638:SRV'
IMD+F+++::Product Description'
QTY+47:84'
MOA+128:5584.38'
MOA+203:5584.38'
MOA+369:0'
PRI+1E:66.4807'
UNS+S'
CNT+2:12'
MOA+39:64434.51'
MOA+128:64434.51'
MOA+369:0.00'
UNT+99+364795'
UNZ+1+364795'

Branching Diagram : INVOIC(Invoice message)

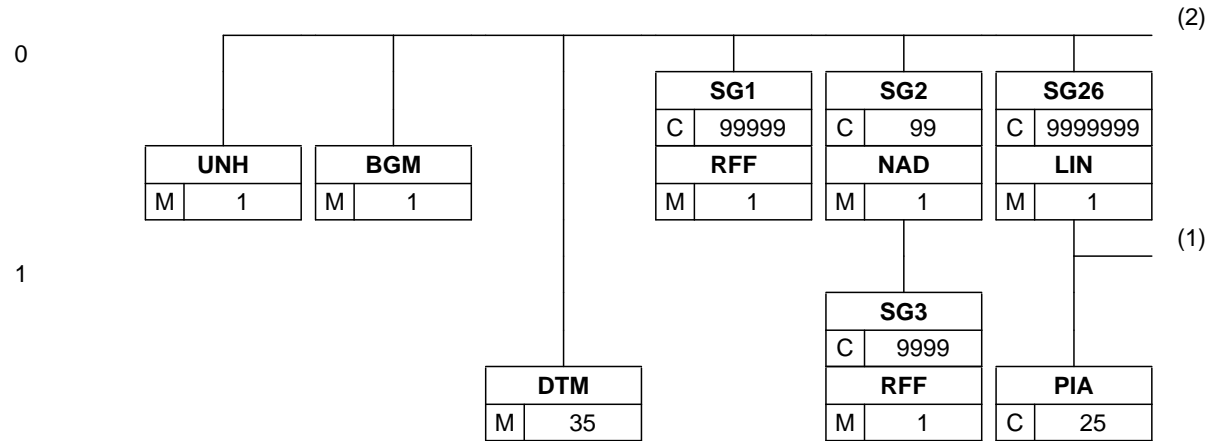

Branching Diagram : INVOIC(Invoice message)

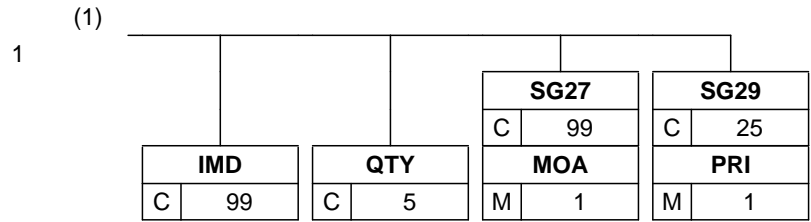

Branching Diagram : INVOIC(Invoice message)

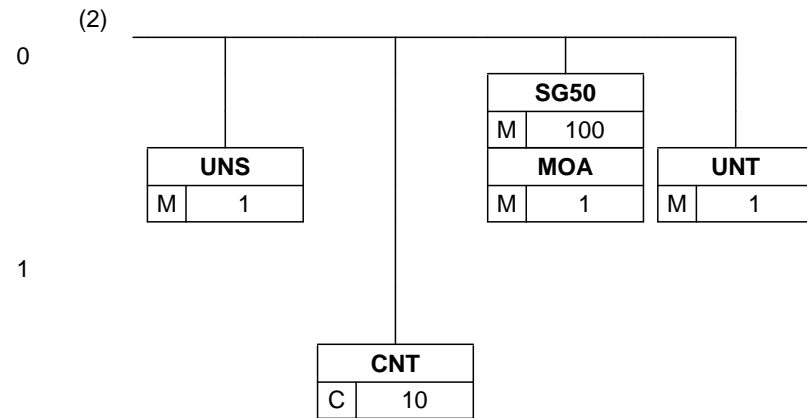

UNH MESSAGE HEADER

Pos: 0010	Max: 1
Mandatory	
Group: N/A	Elements: 2

User Option (Usage): Must use

Function: To head, identify and specify a message.

Element Summary:

<u>Ref</u>	<u>Tag</u>	<u>Element Name</u>	<u>Status</u>	<u>Type</u>	<u>Min/Max</u>	<u>Usage</u>
UNH010	0062	Message reference number	M	an	1/14	Must use
Description: Unique message reference assigned by the sender.						
UNH020	S009	MESSAGE IDENTIFIER	M	Comp		Must use
Description: Identification of the type, version, etc. of the message being interchanged.						
UNH020-01 0	0065	Message type	M	an	1/6	Must use
Description: Code identifying a type of message and assigned by its controlling agency.						
Code List Summary (Total Codes: 210, Included: 1)						
Code Name						
INVOIC Invoice message						
UNH020-02 0	0052	Message version number	M	an	1/3	Must use
Description: Version number of a message type.						
Code List Summary (Total Codes: 8, Included: 1)						
Code Name						
D Draft version/UN/EDIFACT Directory						
UNH020-03 0	0054	Message release number	M	an	1/3	Must use
Description: Release number within the current message version number.						
Code List Summary (Total Codes: 25, Included: 1)						
Code Name						
01B Release 2001 - B						
UNH020-04 0	0051	Controlling agency, coded	M	an	1/3	Must use
Description: Code identifying a controlling agency.						
Code List Summary (Total Codes: 26, Included: 1)						
Code Name						
UN UN/CEFACT						
UNH020-05 0	0057	Association assigned code	C	an	1/6	Used
Description: Code, assigned by the association responsible for the design and maintenance of the message type concerned, which further identifies the message.						

Notes:

1. Data element S009/0057 is retained for upward compatibility. The use of S016 and/or S017 is encouraged in preference.
2. The combination of the values carried in data elements 0062 and S009 shall be used to identify uniquely the message within its group (if used) or if not used, within its interchange, for the purpose of acknowledgement.

BGM BEGINNING OF MESSAGE

Pos: 0020	Max: 1
Mandatory	
Group: N/A	Elements: 3

User Option (Usage): Must use

Function: To indicate the type and function of a message and to transmit the identifying number.

Element Summary:

<u>Ref</u>	<u>Tag</u>	<u>Element Name</u>	<u>Status</u>	<u>Type</u>	<u>Min/Max</u>	<u>Usage</u>
BGM010	C002	DOCUMENT/MESSAGE NAME	M	Comp		Used
Description: Identification of a type of document/message by code or name. Code preferred.						
BGM010-01 0	1001	Document name code	O	an	1/3	Used
Description: Code specifying the document name.						
Code List Summary (Total Codes: 583, Included: 1)						
<u>Code</u> <u>Name</u>						
388 Tax invoice						
BGM010-04 0	1000	Document name	C	an	1/35	Used
Description: Name of a document.						
BGM020	C106	DOCUMENT/MESSAGE IDENTIFICATION	C	Comp		Used
Description: Identification of a document/message by its number and eventually its version or revision.						
BGM020-01 0	1004	Document identifier	C	an	1/35	Used
Description: To identify a document.						
BGM020-03 0	1060	Revision identifier	C	an	1/6	Used
Description: To identify a revision.						
BGM030	1225	Message function code	C	an	1/3	Used
Description: Code indicating the function of the message.						
Code List Summary (Total Codes: 65, Included: 1)						
<u>Code</u> <u>Name</u>						
9 Original						

DTM DATE/TIME/PERIOD

Pos: 0030	Max: 35
Mandatory	
Group: N/A	Elements: 1

User Option (Usage): Must use

Function: To specify date, and/or time, or period.

Element Summary:

<u>Ref</u>	<u>Tag</u>	<u>Element Name</u>	<u>Status</u>	<u>Type</u>	<u>Min/Max</u>	<u>Usage</u>
DTM010	C507	DATE/TIME/PERIOD	M	Comp		Must use

Description: Date and/or time, or period relevant to the specified date/time/period type.

DTM010-01 0	2005	Date or time or period function code qualifier	M	an	1/3	Must use
----------------	------	--	---	----	-----	----------

Description: Code qualifying the function of a date, time or period.

Code List Summary (Total Codes: 739, Included: 1)

<u>Code</u>	<u>Name</u>
137	Document/message date/time

DTM010-02 0	2380	Date or time or period value	C	an	1/35	Used
----------------	------	------------------------------	---	----	------	------

Description: The value of a date, a date and time, a time or of a period in a specified representation.

DTM010-03 0	2379	Date or time or period format code	C	an	1/3	Used
----------------	------	------------------------------------	---	----	-----	------

Description: Code specifying the representation of a date, time or period.

Code List Summary (Total Codes: 76, Included: 1)

<u>Code</u>	<u>Name</u>
102	CCYYMMDD

RFF REFERENCE

Pos: 0130	Max: 1
Mandatory	
Group: 1	Elements: 1

User Option (Usage): Must use

Function: To specify a reference.

Element Summary:

<u>Ref</u>	<u>Tag</u>	<u>Element Name</u>	<u>Status</u>	<u>Type</u>	<u>Min/Max</u>	<u>Usage</u>
RFF010	C506	REFERENCE	M	Comp		Must use
Description: Identification of a reference.						
RFF010-010	1153	Reference code qualifier	M	an	1/3	Must use
Description: Code qualifying a reference.						
Code List Summary (Total Codes: 760, Included: 2)						
Code Name						
ON Order number (purchase)						
AAK Despatch advice number						
RFF010-020	1154	Reference identifier	C	an	1/70	Used
Description: Identifies a reference.						

NAD NAME AND ADDRESS

Pos: 0230	Max: 1
Mandatory	
Group: 2	Elements: 2

User Option (Usage): Must use

Function: To specify the name/address and their related function, either by C082 only and/or unstructured by C058 or structured by C080 thru 3207.

Element Summary:

<u>Ref</u>	<u>Tag</u>	<u>Element Name</u>	<u>Status</u>	<u>Type</u>	<u>Min/Max</u>	<u>Usage</u>
NAD010	3035	Party function code qualifier	M	an	1/3	Must use

Description: Code giving specific meaning to a party.

Code List Summary (Total Codes: 528, Included: 4)

Code Name

BY Buyer
 IV Invoicee
 ST Ship to
 SU Supplier

NAD020	C082	PARTY IDENTIFICATION DETAILS	C	Comp		Used
--------	------	-------------------------------------	---	------	--	------

Description: Identification of a transaction party by code.

NAD020-01 0	3039	Party identifier	M	an	1/35	Must use
----------------	------	------------------	---	----	------	----------

Description: Code specifying the identity of a party.

NAD020-03 0	3055	Code list responsible agency code	C	an	1/3	Used
----------------	------	-----------------------------------	---	----	-----	------

Description: Code specifying the agency responsible for a code list.

Code List Summary (Total Codes: 289, Included: 2)

Code Name

9 EAN (International Article Numbering association)
 92 Assigned by buyer or buyer's agent

RFF REFERENCE

Pos: 0280	Max: 1
Mandatory	
Group: 3	Elements: 1

User Option (Usage): Must use

Function: To specify a reference.

Element Summary:

<u>Ref</u>	<u>Tag</u>	<u>Element Name</u>	<u>Status</u>	<u>Type</u>	<u>Min/Max</u>	<u>Usage</u>
RFF010	C506	REFERENCE	M	Comp		Must use
Description: Identification of a reference.						
RFF010-010	1153	Reference code qualifier	M	an	1/3	Must use
Description: Code qualifying a reference.						
Code List Summary (Total Codes: 760, Included: 1)						
Code Name						
AMT Goods and Services Tax identification number						
RFF010-020	1154	Reference identifier	C	an	1/70	Used
Description: Identifies a reference.						

LIN LINE ITEM

Pos: 1100	Max: 1
Mandatory	
Group: 26	Elements: 2

User Option (Usage): Must use

Function: To identify a line item and configuration.

Element Summary:

<u>Ref</u>	<u>Tag</u>	<u>Element Name</u>	<u>Status</u>	<u>Type</u>	<u>Min/Max</u>	<u>Usage</u>
LIN010	1082	Line item identifier	C	an	1/6	Used
		Description: To identify a line item.				
LIN030	C212	ITEM NUMBER IDENTIFICATION	C	Comp		Used
		Description: Goods identification for a specified source.				
LIN030-010	7140	Item identifier	C	an	1/35	Used
		Description: To identify an item.				
LIN030-020	7143	Item type identification code	C	an	1/3	Used
		Description: Coded identification of an item type.				
		Code List Summary (Total Codes: 104, Included: 1)				
		Code Name				
		SRV EAN.UCC Global Trade Item Number				

PIA ADDITIONAL PRODUCT ID

Pos: 1110	Max: 25
Conditional	
Group: 26	Elements: 6

User Option (Usage): Used

Function: To specify additional or substitutional item identification codes.

Element Summary:

<u>Ref</u>	<u>Tag</u>	<u>Element Name</u>	<u>Status</u>	<u>Type</u>	<u>Min/Max</u>	<u>Usage</u>
PIA010	4347	Product identifier code qualifier	M	an	1/3	Must use
		Description: Code qualifying the product identifier. All valid standard codes are used. (Total Codes: 12)				
PIA020	C212	ITEM NUMBER IDENTIFICATION	M	Comp		Must use
		Description: Goods identification for a specified source.				
PIA020-010	7140	Item identifier	C	an	1/35	Used
		Description: To identify an item.				
PIA020-020	7143	Item type identification code	C	an	1/3	Used
		Description: Coded identification of an item type. All valid standard codes are used. (Total Codes: 104)				
PIA030	C212	ITEM NUMBER IDENTIFICATION	C	Comp		Used
		Description: Goods identification for a specified source.				
PIA030-010	7140	Item identifier	C	an	1/35	Used
		Description: To identify an item.				
PIA030-020	7143	Item type identification code	C	an	1/3	Used
		Description: Coded identification of an item type. All valid standard codes are used. (Total Codes: 104)				
PIA030-030	1131	Code list identification code	C	an	1/17	Used
		Description: Code identifying a user or association maintained code list. All valid standard codes are used. (Total Codes: 247)				
PIA030-040	3055	Code list responsible agency code	C	an	1/3	Used
		Description: Code specifying the agency responsible for a code list. All valid standard codes are used. (Total Codes: 289)				
PIA040	C212	ITEM NUMBER IDENTIFICATION	C	Comp		Used
		Description: Goods identification for a specified source.				
PIA040-010	7140	Item identifier	C	an	1/35	Used
		Description: To identify an item.				
PIA040-020	7143	Item type identification code	C	an	1/3	Used
		Description: Coded identification of an item type. All valid standard codes are used. (Total Codes: 104)				
PIA040-030	1131	Code list identification code	C	an	1/17	Used
		Description: Code identifying a user or association maintained code list. All valid standard codes are used. (Total Codes: 247)				

<u>Ref</u>	<u>Tag</u>	<u>Element Name</u>	<u>Status</u>	<u>Type</u>	<u>Min/Max</u>	<u>Usage</u>
PIA040-040	3055	Code list responsible agency code	C	an	1/3	Used
		Description: Code specifying the agency responsible for a code list. All valid standard codes are used. (Total Codes: 289)				
PIA050	C212	ITEM NUMBER IDENTIFICATION	C	Comp		Used
		Description: Goods identification for a specified source.				
PIA050-010	7140	Item identifier	C	an	1/35	Used
		Description: To identify an item.				
PIA050-020	7143	Item type identification code	C	an	1/3	Used
		Description: Coded identification of an item type. All valid standard codes are used. (Total Codes: 104)				
PIA050-030	1131	Code list identification code	C	an	1/17	Used
		Description: Code identifying a user or association maintained code list. All valid standard codes are used. (Total Codes: 247)				
PIA050-040	3055	Code list responsible agency code	C	an	1/3	Used
		Description: Code specifying the agency responsible for a code list. All valid standard codes are used. (Total Codes: 289)				
PIA060	C212	ITEM NUMBER IDENTIFICATION	C	Comp		Used
		Description: Goods identification for a specified source.				
PIA060-010	7140	Item identifier	C	an	1/35	Used
		Description: To identify an item.				
PIA060-020	7143	Item type identification code	C	an	1/3	Used
		Description: Coded identification of an item type. All valid standard codes are used. (Total Codes: 104)				
PIA060-030	1131	Code list identification code	C	an	1/17	Used
		Description: Code identifying a user or association maintained code list. All valid standard codes are used. (Total Codes: 247)				
PIA060-040	3055	Code list responsible agency code	C	an	1/3	Used
		Description: Code specifying the agency responsible for a code list. All valid standard codes are used. (Total Codes: 289)				

IMD ITEM DESCRIPTION

Pos: 1130	Max: 99
Conditional	
Group: 26	Elements: 2

User Option (Usage): Used

Function: To describe an item in either an industry or free format.

Element Summary:

<u>Ref</u>	<u>Tag</u>	<u>Element Name</u>	<u>Status</u>	<u>Type</u>	<u>Min/Max</u>	<u>Usage</u>
IMD010	7077	Description format code	C	an	1/3	Used
Description: Code specifying the format of a description.						
Code List Summary (Total Codes: 8, Included: 1)						
Code Name						
F Free-form						
IMD030	C273	ITEM DESCRIPTION	C	Comp		Used
Description: Description of an item.						
IMD030-040	7008	Item description	C	an	1/256	Used
Description: Free form description of an item.						

QTY QUANTITY

Pos: 1150	Max: 5
Conditional	
Group: 26	Elements: 1

User Option (Usage): Used

Function: To specify a pertinent quantity.

Element Summary:

<u>Ref</u>	<u>Tag</u>	<u>Element Name</u>	<u>Status</u>	<u>Type</u>	<u>Min/Max</u>	<u>Usage</u>
QTY010	C186	QUANTITY DETAILS	M	Comp		Must use
Description: Quantity information in a transaction, qualified when relevant.						
QTY010-010	6063	Quantity type code qualifier	M	an	1/3	Must use
Description: Code qualifying the type of quantity.						
Code List Summary (Total Codes: 450, Included: 1)						
Code Name						
47 Invoiced quantity						
QTY010-020	6060	Quantity	M	an	1/35	Must use
Description: Alphanumeric representation of a quantity.						
QTY010-030	6411	Measurement unit code	C	an	1/3	Used
Description: Code specifying the unit of measurement.						

MOA MONETARY AMOUNT

Pos: 1260	Max: 1
Mandatory	
Group: 27	Elements: 1

User Option (Usage): Must use

Function: To specify a monetary amount.

Element Summary:

<u>Ref</u>	<u>Tag</u>	<u>Element Name</u>	<u>Status</u>	<u>Type</u>	<u>Min/Max</u>	<u>Usage</u>
MOA010	C516	MONETARY AMOUNT	M	Comp		Must use
Description: Amount of goods or services stated as a monetary amount in a specified currency.						
MOA010-01 0	5025	Monetary amount type code qualifier	M	an	1/3	Must use
Description: Code qualifying the type of monetary amount.						
Code List Summary (Total Codes: 525, Included: 3)						
Code Name						
128 Total amount						
203 Line item amount						
369 Goods and services tax						
MOA010-02 0	5004	Monetary amount	C	n	1/35	Used
Description: To specify a monetary amount.						
MOA010-03 0	6345	Currency identification code	C	an	1/3	Used
Description: Code specifying a monetary unit.						

PRI PRICE DETAILS

Pos: 1340	Max: 1
Mandatory	
Group: 29	Elements: 1

User Option (Usage): Must use
Function: To specify price information.

Element Summary:

<u>Ref</u>	<u>Tag</u>	<u>Element Name</u>	<u>Status</u>	<u>Type</u>	<u>Min/Max</u>	<u>Usage</u>
PRI010	C509	PRICE INFORMATION	C	Comp		Used
Description: Identification of price type, price and related details.						
PRI010-010	5125	Price code qualifier	M	an	1/3	Must use
Description: Code qualifying a price.						
Code List Summary (Total Codes: 10, Included: 1)						
Code Name						
AAA Calculation net						
PRI010-020	5118	Price amount	C	n	1/15	Used
Description: To specify a price.						
PRI010-050	5284	Unit price basis value	C	n	1/9	Used
Description: To specify the basis for a unit price.						
PRI010-060	6411	Measurement unit code	C	an	1/3	Used
Description: Code specifying the unit of measurement.						

UNS SECTION CONTROL

Pos: 2170	Max: 1
Mandatory	
Group: N/A	Elements: 1

User Option (Usage): Must use

Function: To separate header, detail and summary sections of a message.

Element Summary:

<u>Ref</u>	<u>Tag</u>	<u>Element Name</u>	<u>Status</u>	<u>Type</u>	<u>Min/Max</u>	<u>Usage</u>
UNS010	0081	Section identification	M	a	1/1	Must use

Description: Identification of the separation of sections of a message.

Code List Summary (Total Codes: 2, Included: 1)

Code Name

S Detail/summary section separation

Notes:

1. To be used by message designers only when required to avoid ambiguities.

CNT CONTROL TOTAL

Pos: 2180	Max: 10
Conditional	
Group: N/A	Elements: 1

User Option (Usage): Used
Function: To provide control total.

Element Summary:

<u>Ref</u>	<u>Tag</u>	<u>Element Name</u>	<u>Status</u>	<u>Type</u>	<u>Min/Max</u>	<u>Usage</u>
CNT010	C270	CONTROL	M	Comp		Must use
Description: Control total for checking integrity of a message or part of a message.						
CNT010-010	6069	Control total type code qualifier	M	an	1/3	Must use
Description: Code qualifying the type of control of hash total.						
Code List Summary (Total Codes: 57, Included: 1)						
Code Name						
2 Number of line items in message						
CNT010-020	6066	Control total value	M	n	1/18	Must use
Description: To specify the value of a control quantity.						

MOA MONETARY AMOUNT

Pos: 2200	Max: 1
Mandatory	
Group: 50	Elements: 1

User Option (Usage): Must use

Function: To specify a monetary amount.

Element Summary:

<u>Ref</u>	<u>Tag</u>	<u>Element Name</u>	<u>Status</u>	<u>Type</u>	<u>Min/Max</u>	<u>Usage</u>
MOA010	C516	MONETARY AMOUNT	M	Comp		Must use
Description: Amount of goods or services stated as a monetary amount in a specified currency.						
MOA010-01 0	5025	Monetary amount type code qualifier	M	an	1/3	Must use
Description: Code qualifying the type of monetary amount.						
Code List Summary (Total Codes: 525, Included: 4)						
Code Name						
39 Invoice total amount						
86 Message total monetary amount						
128 Total amount						
369 Goods and services tax						
MOA010-02 0	5004	Monetary amount	C	n	1/35	Used
Description: To specify a monetary amount.						
MOA010-03 0	6345	Currency identification code	C	an	1/3	Used
Description: Code specifying a monetary unit.						

UNT MESSAGE TRAILER

Pos: 2320	Max: 1
Mandatory	
Group: N/A	Elements: 2

User Option (Usage): Must use

Function: To end and check the completeness of a message.

Element Summary:

<u>Ref</u>	<u>Tag</u>	<u>Element Name</u>	<u>Status</u>	<u>Type</u>	<u>Min/Max</u>	<u>Usage</u>
UNT010	0074	Number of segments in a message	M	n	1/10	Must use
		Description: The number of segments in a message body, plus the message header segment and message trailer segment.				
UNT020	0062	Message reference number	M	an	1/14	Must use
		Description: Unique message reference assigned by the sender.				

Notes:

- 0062, the value shall be identical to the value in 0062 in the corresponding UNH segment.